

Supplementary Material for "Partially-supervised
protein subclass discovery with simultaneous
annotation of functional residues"

October 19, 2009



Figure 1: Phylogenetic tree of the analysed pyridoxal-dependent decarboxylases. Glutamate decarboxylases (EC: 4.1.1.15) are highlighted in blue, tyrosine decarboxylases (EC: 4.1.1.25) in yellow. Bootstrap support for the main branches is shown. MFNA_PYRFU and MFNA_PYRAB were excluded from the tree as they did not cover the whole decarboxylase domain.

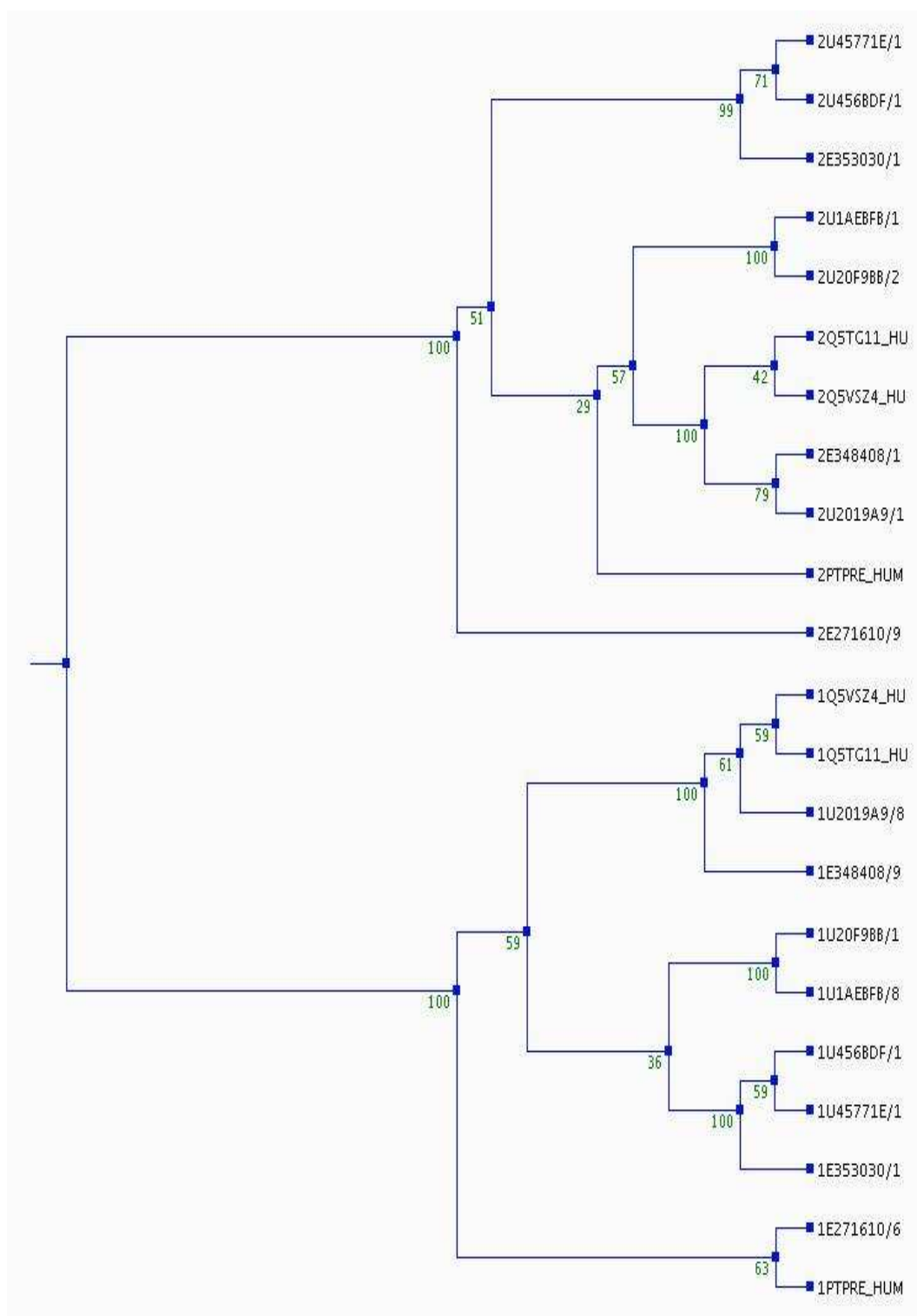

Figure 2: Bootstrap tree for the receptor tyrosine phosphatase data set.

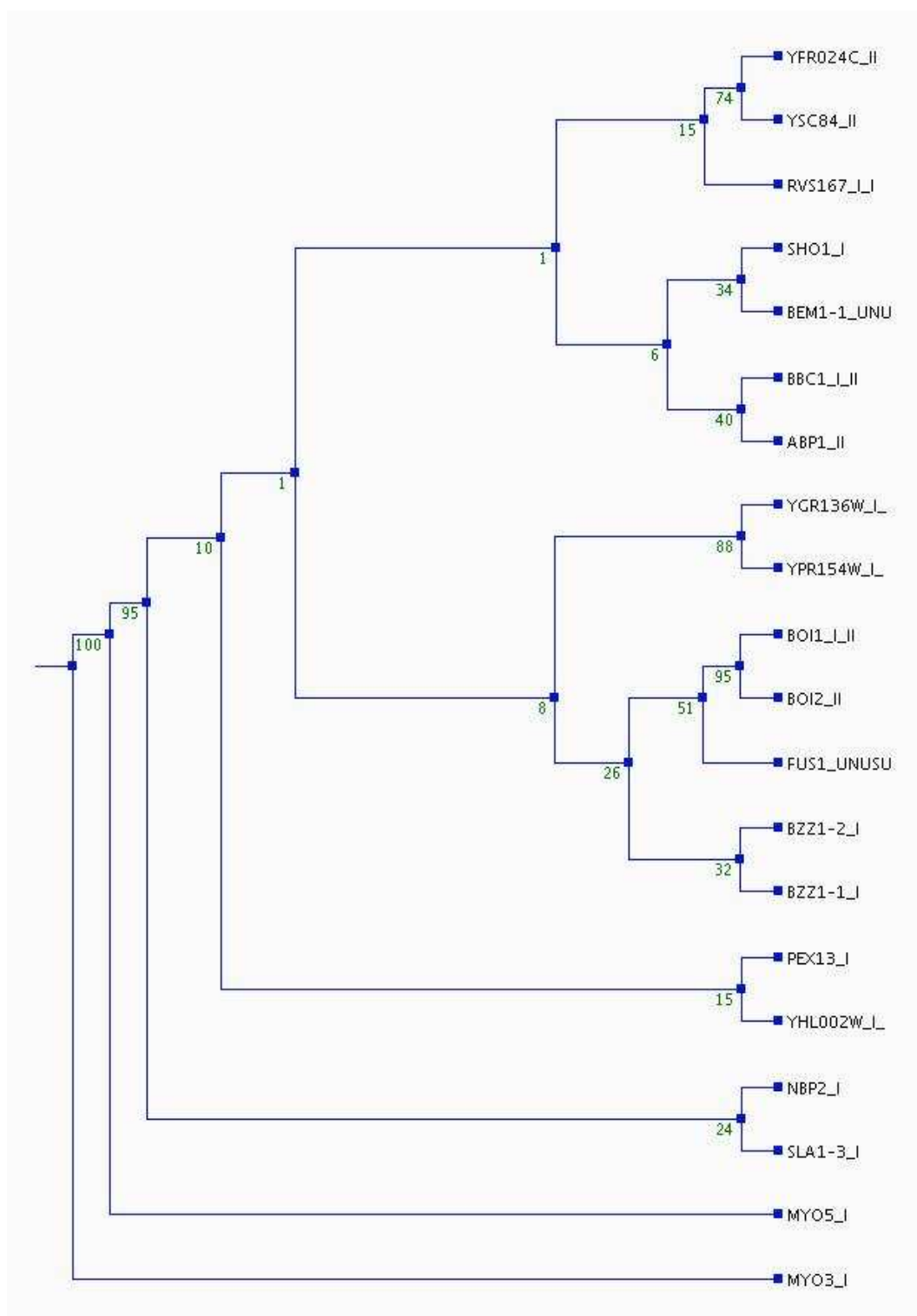

Figure 3: Bootstrap tree for the SH3 data set.

